

# MASCOT

## 21" Silent Cut Reel Mower OWNERS MANUAL

MODEL **45-0252LW**

10" Large Wheels

MODEL **45-0252SW**

9" Small Wheels

### **IMPORTANT:**

Read all instructions  
carefully before assembling  
and using this product.



**For Repair Parts Call:**

---

Mascot Sharpening & Sales  
434-B Newport Road  
Ronks, PA 17572  
717-656-6486

# Rules for Safe Operation

## Read this entire manual before assembling and using your reel mower.

- Allow only those persons who have read and understood these safety rules to use the mower.
- Make sure the mower is in safe operating condition before each use. Make sure all nuts, bolts and screws are tight. Make necessary adjustments and repair any damage before use.
- Inspect the lawn and remove any sticks, stones, wire, bones or other debris before mowing. Such objects can be thrown by the mower giving injury to someone or causing the reel to stop suddenly, damaging the mower.
- Store and use the mower away from the reach of small children, the blades are sharp.
- Wear substantial only footwear when using the mower, never sandals, slippers or bare feet.
- Keep hands and feet away from the blades and moving parts of the mower at all times.
- Mow only in daylight or good artificial light.
- Mow only dry grass, never damp or wet grass.
- Keep both hands on the handles and maintain solid footing at all times, always walk, never run.
- Mow across the face of slopes, never up or down. Exercise extreme caution when changing direction on slopes. Do not mow extremely steep slopes.
- Avoid striking trees, fences, curbs, lawn borders or other objects as this can cause injury or damage the mower.
- Mower must be properly lubricated and sharpened in order to operate safely and efficiently.

## CARTON CONTENTS

### Loose Parts in Carton

1. Upper Handle (2)
2. Handle Panel
3. Handle Brace (2)
4. Reel Assembly
5. Hardware Package

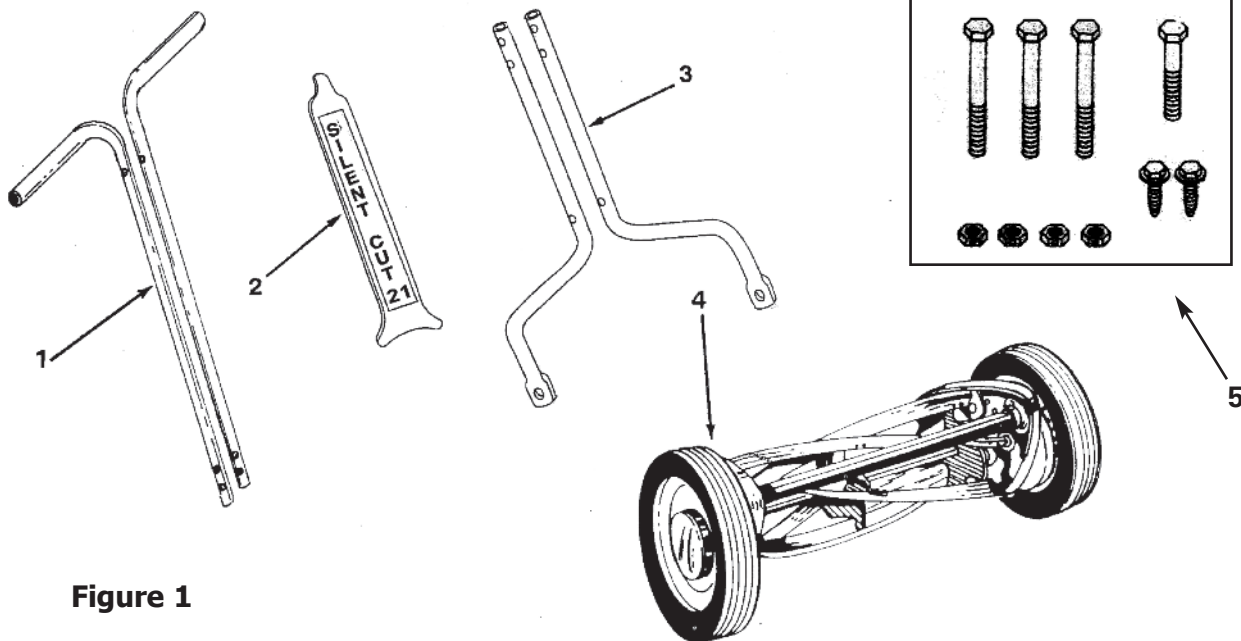

Figure 1

# Assembly Instructions

## Tools required for assembly

- Open or boxed end wrench
- Pair of pliers or vise grips

1. Arrange carton contents as shown in figure 1 on page two, and hardware as shown in figure 1 on page 2.
2. Insert the short end of the two handle braces through the slots and over the two pins in the end plates as shown in figure 2 below.
3. Insert a 5/16 x 2 3/4 inch bolt thru braces and hand tighten the nut (fig.3)
4. Attach the two upper handles to the handle braces with two 5/16-18 x 2 3/4 inch bolts as shown in figure 4. Hand tighten the nuts.
5. Assemble the upper handles at the top with a 5/16 x 2 1/2 inch bolt and nut. Hand tighten.
6. Place the handle panel over the handle and insert the 12 x 1 screws into the notches between the handle braces and the upper handles (fig.5)
7. Tighten all four handle bolts and nuts as shown in figures 3 and 4. If necessary, retighten the 12 x 1 screws into the handle panel.

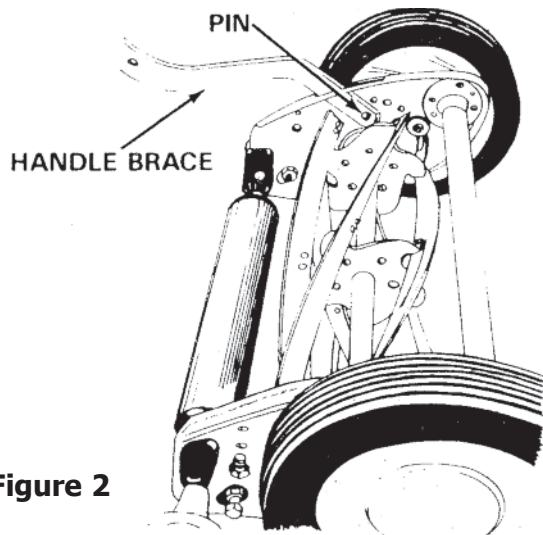

Figure 2

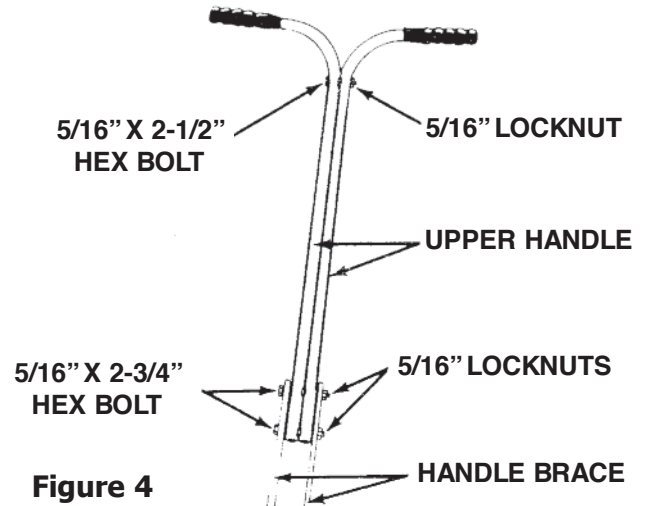

Figure 4

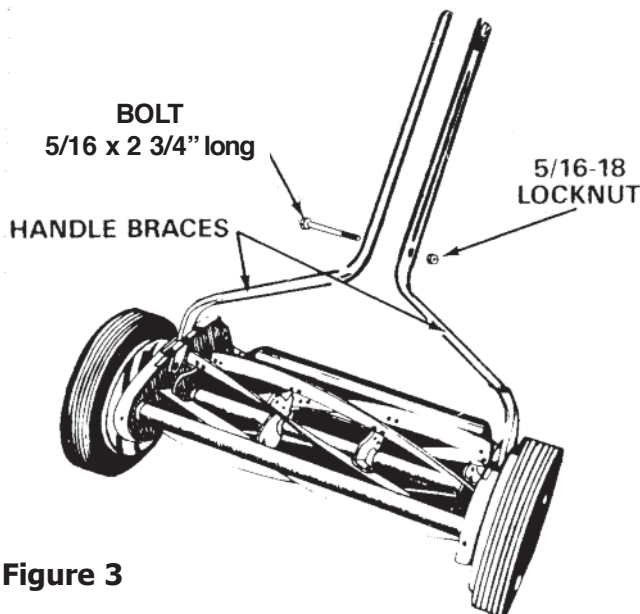

Figure 3

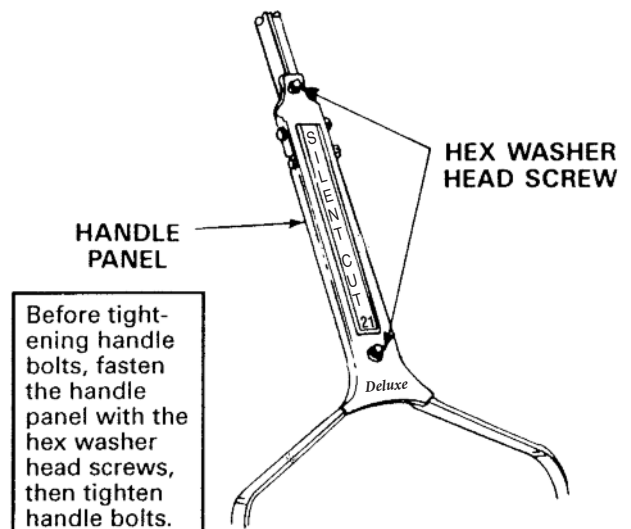

Figure 5

# Cutter Bar Adjustment

The cutter bar on your mower was professionally adjusted before it left our shop. Many years of experience tell us that light contact provides a superior cut and the mower can go longer without needing to be sharpened when set this way.

Some customers have reported that their mower was a little difficult to push the first time they used it but that it quickly became easier. Spraying the reel blades with WD40 or another lubricant will reduce the friction between the blades, making the mower easier to push and minimizing wear of the blades.

After considerable use or sharpening, the cutter bar may need adjustment. This requires a 9/16" wrench.

Make certain that the bolts which are threaded into the cutter bar are tight, to eliminate any play or looseness, before beginning adjustment of the cutter bar (fig.6) The short cutter bar bolt (A) must be turned counter clockwise to tighten on the side shown in figure 6. The cutter bar bolt on the opposite side has a regular thread.

To adjust the cutter bar push the handle of the mower forward and let it rest on the ground. The roller will be off the ground (fig.7)

Using a 9/16" wrench, turn the adjustment nut approx. 1/8 turn clockwise to increase the contact between the reel bedknife (fig.6). Turn the adjustment nut counterclockwise 1/8" turn to decrease the contact between the reel and bedknife. Adjust each side equally until there is minimal contact.

It is important that the cutter bar be set so that the contact is even across the cutter bar, from one side of the mower to the other. You can test this by slowly turning the reel and listening to the sound of the reel blades as they contact the cutter bar, or you can use the paper test described on this page (fig.7).

Insert a strip of quality 0.003" paper such as writing paper or a magazine page, approximately 2" wide and 6" long, between the cutter bar and the reel blades (fig.7). Turn the reel slowly and carefully, inserting the paper at intervals across the reel. The reel will turn easily and will cut the paper all the way across the cutter bar.

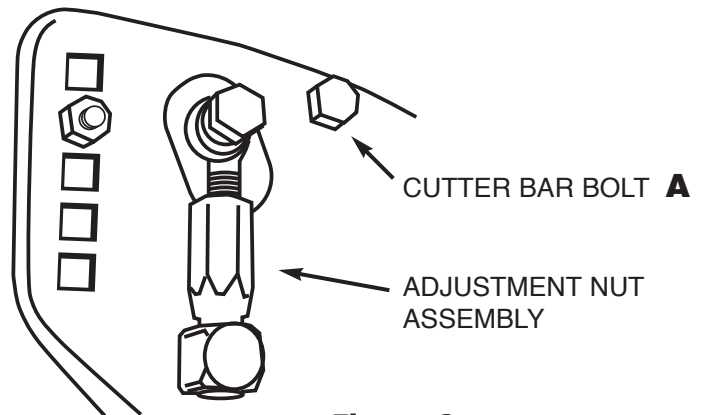

Figure 6

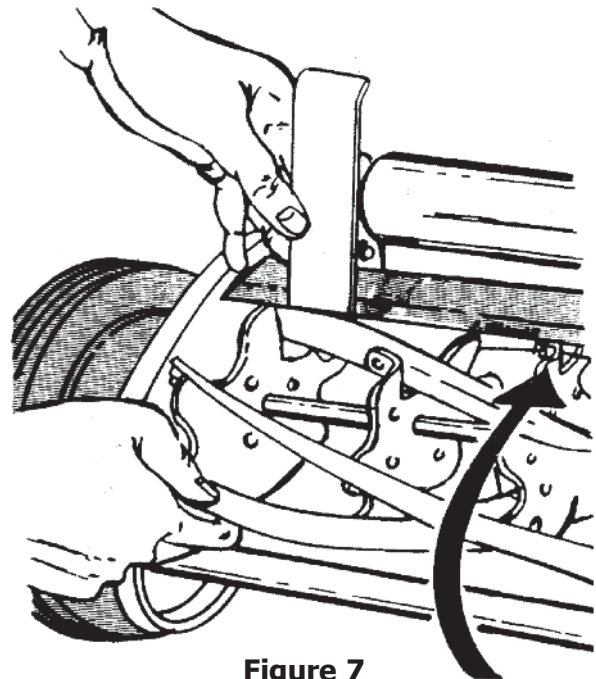

Figure 7



## NOTE

Keeping the bed-knife adjusted so that the blades contact slightly, will extend the sharpness of the mower. This is very easy to do and should be done on a regular basis.

# Choosing the Cutting Height

Choosing the best cutting height is one of the most important decisions you will make for the health and beauty of your lawn. The best sources of information about lawn care are universities, seed and sod producers, departments of agriculture and the volunteers with the nationwide Master Gardener program. Climate and soil can affect this decision, so the best information comes from a regional source such as the local Master Gardeners. When you locate a credible source of information you will find that they usually give a range of recommended mowing heights, such as "1.5 to 3 inches". Choosing a height at the higher end of that range has many benefits. The blades of grass act as solar collectors; they feed the plant, so taller grass is providing more energy for the lawn and encourages deeper root systems. Deeper roots mean the lawn will be more drought tolerant because during dry spells, it is the surface that dries out fastest, so the deeper soil contains more water.

Taller grass tends to invite fewer weeds. Some

weed seeds must have direct sunlight to sprout, so the shading effect of the taller grass can prevent these weeds from even getting started. Others will simply be crowded out by the tall grass.

Another benefit is the frequency of mowing required. It is best to mow often enough that you are not cutting off more than one third of the length of the blade in any mowing. If you mow to a finished height of 1.5" then you must mow every time the grass grows a half inch. If you mow to a finished height of 3" then you only have to mow every time the grass grows an inch.

Weeds tend to grow faster than grass, so mowing more often will help to prevent those towering weeds that don't get caught between the reel blades and the cutter bar, and therefore do not get cut. Your taller grass will be greener, healthier, need less water, have fewer weeds and will filter out more pollutants and produce more oxygen than a lawn that is mowed too severely. © Marjorie King, 2009

## Cutting Height Adjustment

To adjust your mower to your desired cutting height you can either change the gear housing (Fig. 8) or you can change the roller knob (Fig. 9)

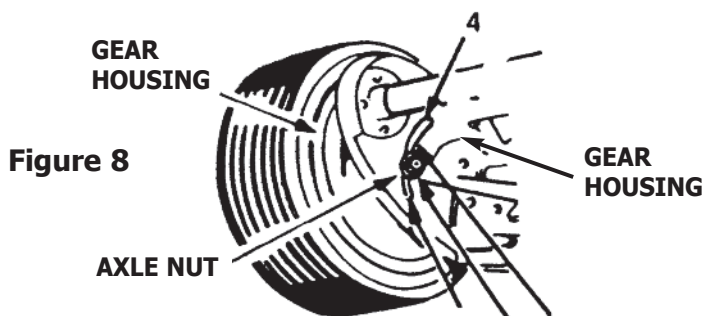

Figure 8

You can adjust height either at roller or as described above

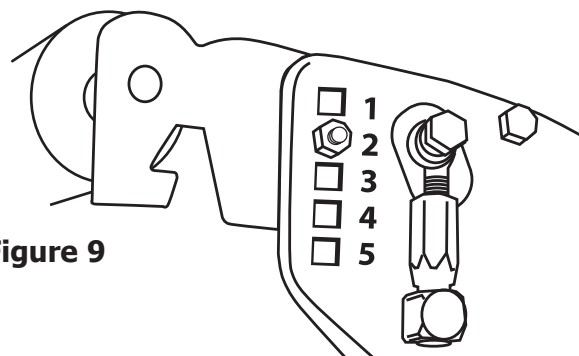

Figure 9

To adjust the gear housing, tilt the mower back so that it is resting on the handle and roller. Use a 1/2" wrench to loosen the nut approx. 2 turns. Put the gear housing to the desired position and retighten the 1/2" nut. Repeat this step on the opposite side. Be sure that both sides are at the same position and are firmly seated in the notch.

To adjust the roller knobs, tilt the mower forward so that it is resting on the handle and the wheels, the roller is up. Use a 1/2" wrench and loosen the nuts on either side and move the roller to the desired position and retighten the nuts. Be sure that both sides are in the same position.

Figure 9

### Model #45-0252LW (large wheel) Settings

Cut Height in Inches	Roller Setting	Wheel Setting
1	2	4
1 1/4	5	3
1 1/2	3	3
1 3/4	1	3
2	4	2
2 1/4	3	2
2 1/2	2	2
2 3/4	3	1
3	1	1

**Model 45-0252SW (small wheel) mower cuts 1/2" shorter on all above cut height settings.**

# Maintenance

## Lubrication

Lubricate the wheels and gears once a season and whenever the reel is sharpened.

Tools required are a standard screwdriver, snap ring pliers, light grease and engine oil, and if rust is present, solvent and crocus cloth.

1. Remove the hub cap using the screwdriver.
2. Remove the e-ring with the screwdriver.
3. Lift off the wheel.
4. Clean rust, if any, from axle, using solvent and crocus cloth.
5. Coat the axle with light grease.
6. Remove the snap ring on the pinion gear, being careful not to loose the ratchet pawl under the pinion gear. It is important to use snap ring pliers in order to prevent damaging the snap ring.
7. Remove the pawl from the reel shaft, noting the exact position it is in. It must be reinstalled in the same position in order to drive the wheel.
8. Apply light grease to the gear teeth on the inside of the wheel Figure 12.
9. Using engine oil, lightly lubricate points indicated in Figures 10 & 11 on roller and between end plates and wheel dust covers. Periodic lubrication on these points will ensure smooth mechanical operation.

Figure 10

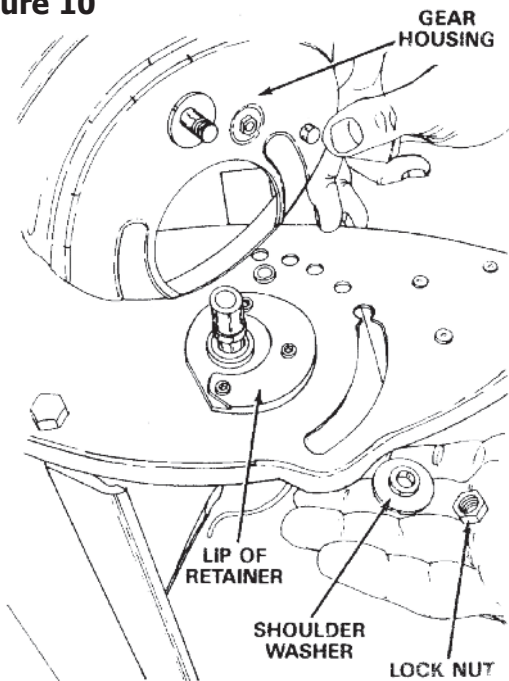

## Sharpen Blades

Your Silent Cut reel mower features high quality heat-treated reel and bedknife blades that were professionally sharpened before leaving our shop. Signs that the mower needs to be sharpened include:

The mower will start to become more difficult to push.

When properly sharpened and adjusted, the mower will cut the grass with a clean cut straight across the blade. Dull blades will leave a somewhat ragged cut.

Small dings or light rust on the blades can be removed with sharpening

Always backlap the blades, never use a file.

## Gear Housing Assembly

The gear housing must be properly assembled in order to prevent loose wheels, which will result in early failure of the pinion gears and wheels. When replacing the gear housing after it is removed for service, be sure that it fits UNDER the lip of the retainer. The shoulder on the shoulder washer must fit into the slot on the end plate. Tighten the lock nut.

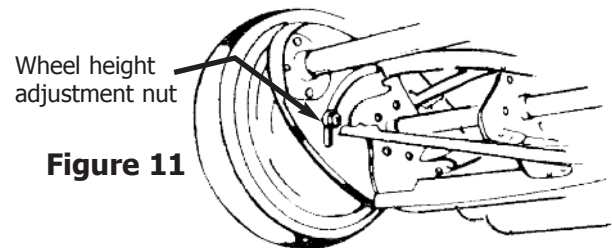

Figure 11

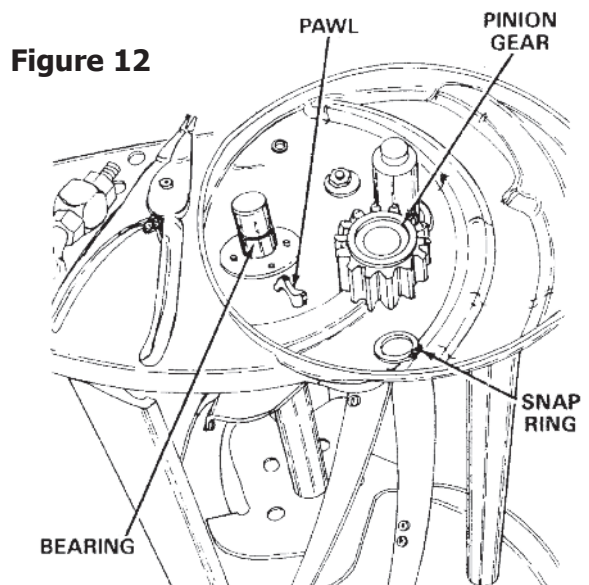
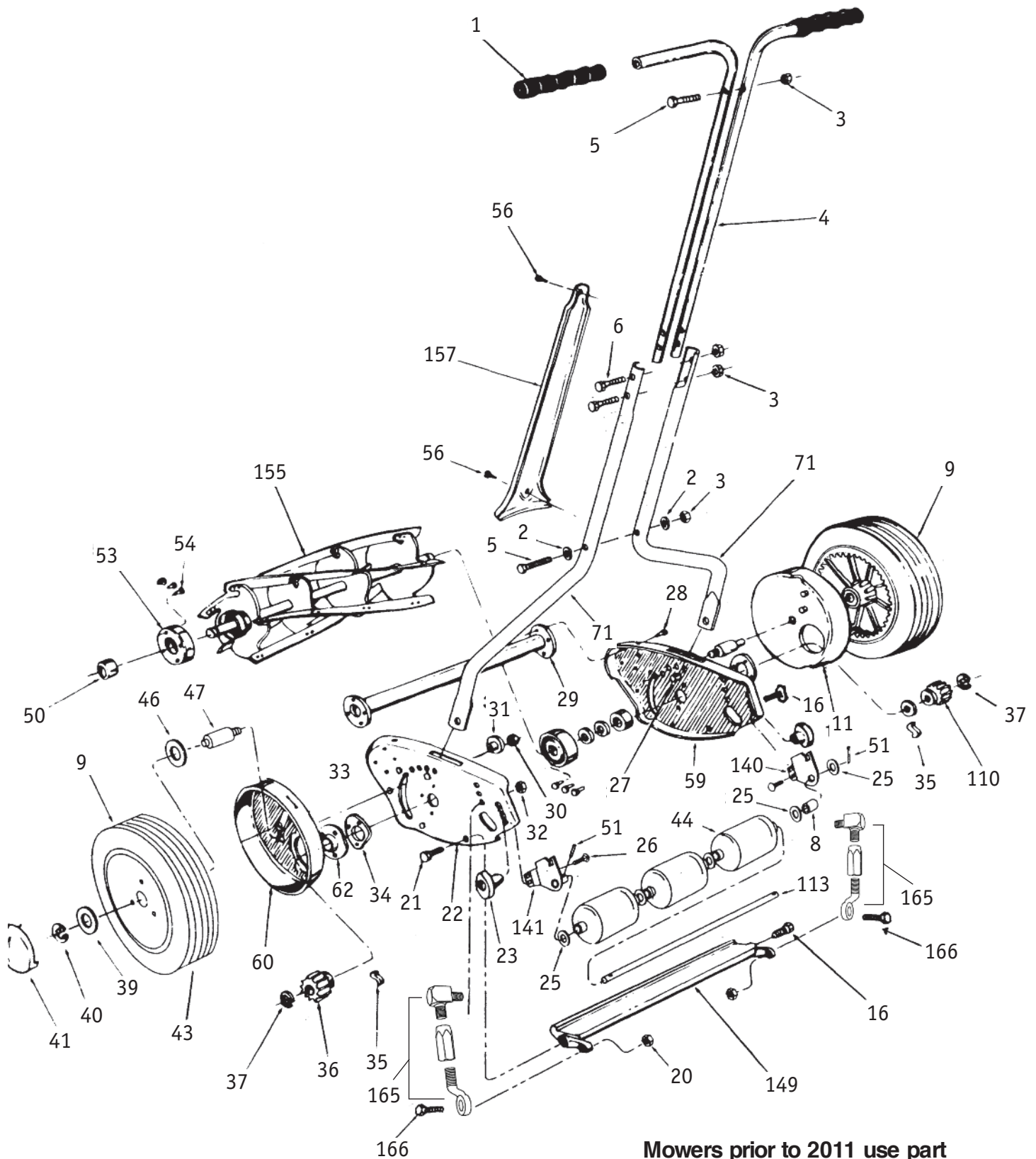

Figure 12

# Repair Parts

Model **45-0252**  
21" Push Reel Mower



Mowers prior to 2011 use part #’s 19, 20, 65, 66 See chart on page 8.

# REPAIR PARTS FOR MODEL NO. 45-0252 21" PUSH REEL MOWER

REF. NO.	PART NO.	QTY.	DESCRIPTION	REF. NO.	PART NO.	QTY.	DESCRIPTION
1	46471	2	Handle Grip	46	44008	2	Inside Wheel Washer
2	43086	2	Lock Washer, 5/16"	47	1631-051	2	Axle
3	43064	4	Nut, Hex Lock 5/16-18 Thd.*	50	44232	2	Reel Bearing
4	46434	2	Upper Handle for 21" Push	51	1548-007	1	Roller Shaft Pin
5	43224	2	Bolt, Hex 5/16-18 x 2-1/4" Lg.*	53	1629-028	2	Retainer Bearing
6	44292	1	Bolt, Hex 5/16-18 x 2-1/2" Lg.*	54	1530-20	6	Rivets, 3/16 Dia. x 13/32" Lg.
8	1697-005		Out Rigger Bar for Gang	55	3135-036	1	21" Reel Assembly
9	1108-95	2	Wheel Assembly	56	44486	2	Handle Plate Screws #10 x 1" Lg.
11	2118-082	1	Gear Housing Assembly - R.H.	59	3111-130	1	End Plate Assembly - R.H.
13	46330	2	Long Trunnion Adj. Screw & Bolt (old style)	60	2118-081	1	Gear Housing Assembly - L.H.
14	43716	1	21" Roller	61	1155-047	2	Wheel Adjustment Lever
16	1509-086	1	Cutter Bar Screw (L.H Thread.)	62	1629-041	2	Pinion Housing
18	46331	2	Long Bolt Bed Knife Adjust. Old Style	46802		1	Owners Manual
19	46329	2	Trunnion, for Adjustment Screw	63	1652-052	4	Plastic Wheel Bearings
20	0052-000	4	Hex Nut 3/8 - 24 Thread	65	0451-000	2	Cutter Bar Adjusting Eye Bolt
21	0455-000	1	Cutter Bar Screw - R.H. Thread	66	0453-000	2	Bed Knife Screw
22	3111-131	1	End Plate Assembly - L.H.	68	2850	1	Complete Handle
23	1643-023	2	Roller Adjustment Knob & Bolt	69	2830		Tube Tongue No J Hook (gang)
24	1609-707	1	Roller Bracket - L.H.	70	3600		Top Gang Bracket (gang only)
25	R19171616	5	Flat Washer, 17/32" x 1"	71	25-21	2	Handle Brace 21" Push
26	43079	2	Carriage Bolts 5/16-18 x 1"	75	3000		2-Step Bushings for Gang Bracket - 2 on each side
27	0010-000	2	Handle Trunnion	80	2840	1	Complete Handle 21" Push
28	44060	8	Pop Rivets	81	2619-034	2	Tire only
29	1112-15	1	Spacer Tube Assembly	110	0425-000	1	Pinion Gear, R.H.
30	44738	2	Hex Lock Nut 5/16-24 Thread	111	2820		Solid Shaft Tongue w/J Hook (gang)
31	1657-019	2	Bushing, Wheel Adjustment	113	1632-84	1	Roller Shaft
32	1118-013	2	Gear Housing - R.H.	114	1129-180		End Plate, L.H.
33	1509-038	2	Hex Screw, #10-32 x 3/8" Lg.	120	1652-052		Old Style Bronze Bearing
34	1624-138	2	Retainer	131	1118-014		Gear Housing, L.H.
35	0323-000	2	Pawl	134	1629-009		Bearing Retainer
36	0428-000	1	Pinion Gear - L.H.	140	2132-045	1	Roller Bracket, R.H.
37	1650-21	2	Retaining Ring	141	2132-044	1	Roller Bracket, L.H.
38	1548-7	1	Roll Pin, 1/8" x 13/64" Lg.	146	1108-095	2	Wheel & Tire
39	1540-118	2	Flat Washer, 3/8" x 1-1/4"	149	3134-024		Cutter Bar
40	1650-001	2	Retaining Ring	155	3135-36		21" Reel Assembly
41	2674-032	2	Hub Cap	157	3622-58	1	Handle Panel
43	2619-025	1	Tire Only	165	2011-2	2	New Style Cutter Bar Adjustment
44	1658-012	3	Roller - each section	166	2011-4	2	Bronze Metal Wheel Bearing
45	1129-181		End Plate, R.H. (21" gang only)				

\* Common hardware may be purchased locally.

**All Axles, Gears, Snap Rings, Bed Knife Bolts same as the Push Mowers.**

**For Repair Parts Call  
Mascot Sharpening & Sales**

434-B Newport Road  
Ronks, PA 17572

**717-656-6486**